



Fitting Instructions For LS0010 LOCKSTOP SAVERS
BMW S1000RR 2019-



Picture A

THIS KIT CONTAINS THE ITEMS PICTURED AND LABELLED OVER PAGE.

SOME PARTS MAY BE SHOWN FOR CLARITY OF INSTRUCTIONS ONLY.

DO NOT PROCEED UNTIL YOU ARE SURE ALL PARTS ARE PRESENT.

PLEASE READ ALL INSTRUCTIONS BEFORE PROCEEDING.

IF IN ANY DOUBT WHEN FITTING OUR PRODUCTS, CONSULT ONE OF OUR

Please note that the way the kit is packed does not necessarily represent the way
 of mounting to the bike.

In the event of rubber washers being used to hold components onto bolts,
 these rubber washers can be thrown away.

DIGITAL COPIES OF THESE INSTRUCTIONS ARE AVAILABLE FROM

www.rg-racing.com

R&G Racing

Unit 1, Shelleys Lane, East Worldham, Alton, Hampshire GU34 3AQ.

Tel: +44 (0)1420 89007 Fax +44 (0)1420 87301 www.rg-racing.com Email: info@rg-racing.com



<u>TOOLS REQUIRED</u>	<u>GENERAL TORQUE SETTINGS</u>
<ul style="list-style-type: none"> • 4mm Allen Key • 10mm spanner or socket. 	<p>M4 BOLT = 8Nm M5 BOLT = 12Nm M6 BOLT = 15Nm M8 BOLT = 20Nm M10 BOLT = 40Nm M12 BOLT = 40Nm</p>

LEGEND

ITEM NO.	DESCRIPTION	QTY
ITEM 1	B0544 LOCKSTOP SAVER BOBBIN	2
ITEM 2	M6 x 25mm COUNTERSUNK BOLT	2
ITEM 3	M6 NYLOC NUTS	2

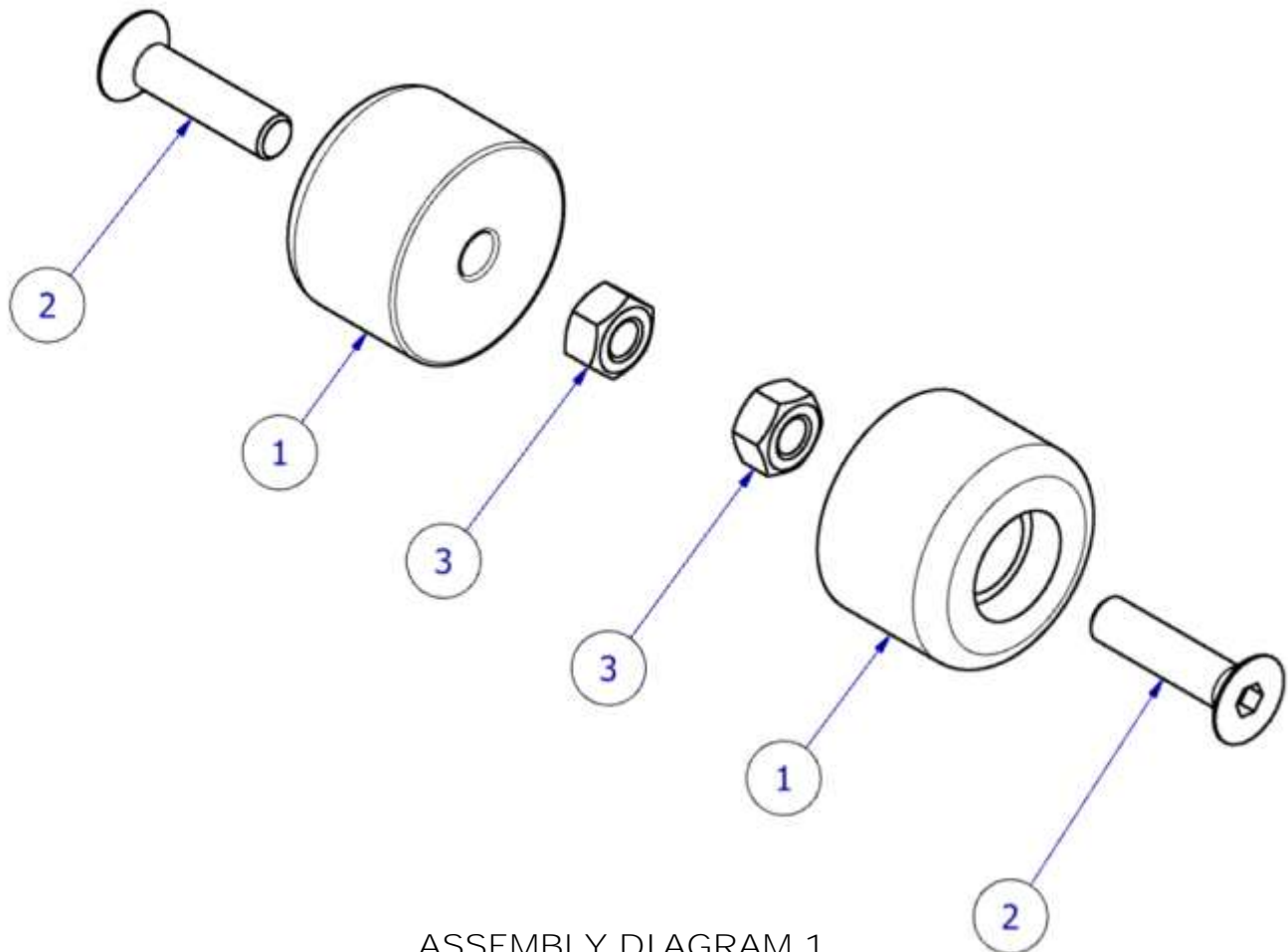

ASSEMBLY DIAGRAM 1

R&G Racing

Unit 1, Shelleys Lane, East Worldham, Alton, Hampshire GU34 3AQ.

Tel: +44 (0)1420 89007 Fax +44 (0)1420 87301 www.rg-racing.com Email: info@rg-racing.com



FITTING INSTRUCTIONS

- Referring to the Assembly Diagram 1 on page 2, place one M6 Countersunk bolt (item 2) through one B0544 Bobbin (Item 1).
- Locate the hole in the frame near the headstock of the motorcycle (arrowed in Picture A on page 1) and place the exposed end of the bolt through the hole so that the flat side of the lockstop saver is on the frame as Picture A with the logo showing to the outside.
- Carefully thread on M6 Nyloc nut (item 3) onto the thread and tighten until it pinches the frame enough to hold the lockstop bobbin in place so it cannot spin. Do not overtighten as the nyloc will hold the bolt tight.
- Repeat for both sides.
- Test your steering to ensure no cables or wiring become trapped between the fork leg and bobbin or catch on the lockstop savers when turned.
- Regularly check to ensure the lockstops remain tight.

ISSUE 1 05/09/2019 (DM)

CONSUMER NOTICE

The catalogue description and any exhibition of samples are only broad indications of the Products and R&G may make design changes which do not diminish their performance or visual appeal and supplying them in such state shall conform to the order. The Buyer acknowledges no representation or warranty (other than as to title) **has been given or will apply to the Products other than those in R&G's order or confirmation and the Buyer confirms it has chosen the Products as being of merchantable quality and suitable for its particular purposes.** Where R&G fits the Products or undertakes other services it shall exercise reasonable skill and care and rectify any fault free of charge unless the workmanship has been disturbed. The Buyer is responsible for ensuring that the warranty on the motorcycle is not affected by the fitting of the Products. On return of any defective Products R&G shall at its option either supply a replacement or refund the purchase money but shall not be **liable if the Products have been modified or used or maintained otherwise than in accordance with R&G's or manufacturer's instructions and good engineering practice or if the defect arises from accident or neglect.** Other than identified above and subject to R&G not limiting its liability for causing death and personal injury, it shall not be liable for indirect or consequential loss and otherwise its liability shall be limited to the amounts paid by **the Buyer for the Products or the fitting or service concerned. These terms do not affect the Buyer's statutory rights.**

R&G RACING RETURNS POLICY (NON-FAULTY GOODS)

Returns must be pre-authorized (if not pre-authorized the return will be rejected). Goods may only be returned direct to us if they were purchased direct from us (customer must prove if necessary). Otherwise to be returned to original vendor. Goods must be in re-sellable condition, in the opinion of R&G Racing. All returns are subject to a 25% restocking and handling fee (25% of the gross value exc. P&P – at the prevailing price at time of purchase). The customer must pay any and all carriage charges. No returns of discontinued products, unless within 14 days of purchase. This policy does not affect your statutory rights and does not refer to faulty goods.

R&G Racing

Unit 1, Shelleys Lane, East Worldham, Alton, Hampshire GU34 3AQ.

Tel: +44 (0)1420 89007 Fax +44 (0)1420 87301 www.rg-racing.com Email: info@rg-racing.com



NOTICE DE MONTAGE POUR LS0010 PROTECTION VERROUILLAGE

BMW S1000RR 2019-



Photo A

LE KIT CONTIENT LES ARTICLES EN PHOTO ET ETIQUETTES SUR LA PAGE

LES PARTIES PRÉSENTÉES PEUVENT ÊTRE UNIQUEMENT REPRESENTATIVES POUR LA CLARTE DES INSTRUCTIONS

NE PAS PROCÉDER AU MONTAGE AVANT DE VOUS ÊTRE ASSURÉ QUE TOUTES LES PIÈCES SOIENT PRÉSENTES.

SVP, LIRE L'ENSEMBLE DE LA NOTICE AVANT DE PROCÉDER AU MONTAGE.

EN CAS DE DOUTE LORS DU MONTAGE, CONSULTEZ UN DE NOS REVENDEURS,

LA FAÇON DONT LE KIT EST EMBALLÉ NE CORRESPOND PAS FORCÉMENT À LA FAÇON DE MONTER LES PIÈCES SUR LA MOTO .

NOTEZ QUE SI LES KITS SONT EMBALLÉS AVEC DES RONDELLES EN CAOUTCHOUC SERVANT À TENIR LES COMPOSANTS, CES RONDELLES DOIVENT ÊTRE JETÉES.

NOTICE DISPONIBLE AU TÉLÉCHARGEMENT SUR : WWW.RG-RACING.COM

R&G Racing

Unit 1, Shelleys Lane, East Worldham, Alton, Hampshire GU34 3AQ.

Tel: +44 (0)1420 89007 Fax +44 (0)1420 87301 www.rg-racing.com Email: info@rg-racing.com



<u>OUTILS REQUIS</u>	<u>VALEURS DE SERRAGE</u>
<ul style="list-style-type: none"> • Clé Allen 4mm • Clé à molette 10mm. 	M4 BOULON = 8Nm M5 BOULON = 12Nm M6 BOULON = 15Nm M8 BOULON = 20Nm M10 BOULON = 40Nm M12 BOULON = 40Nm

LEGENDE

ARTICLE NO.	DESCRIPTION	QTE
ARTICLE 1	B0544 BOBINE DE PROTECTION VERROUILLAGE	2
ARTICLE 2	M6 x 25mm BOULON	2
ARTICLE 3	M6 ECROUS	2

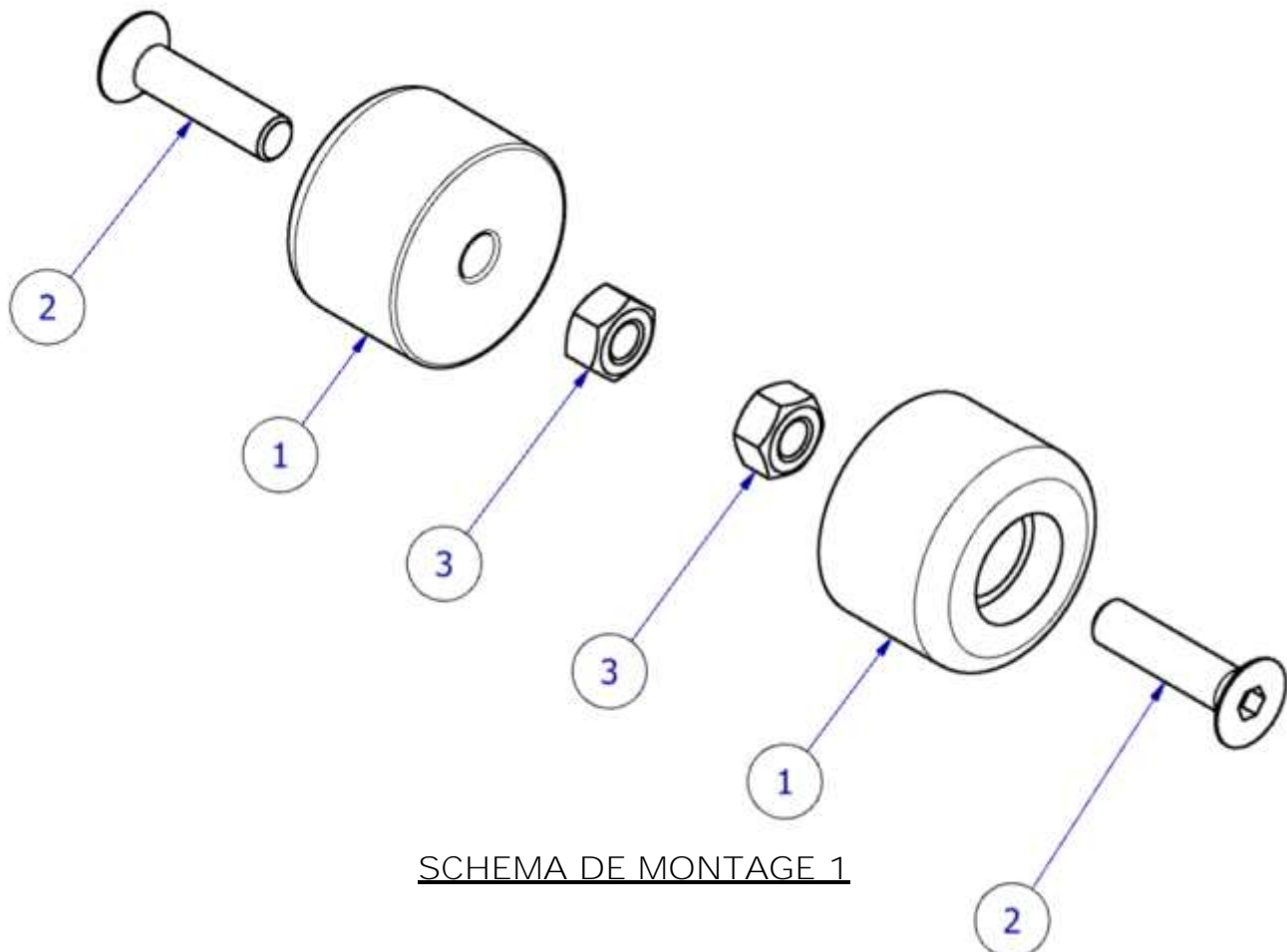

SCHEMA DE MONTAGE 1

R&G Racing

Unit 1, Shelleys Lane, East Worldham, Alton, Hampshire GU34 3AQ.

Tel: +44 (0)1420 89007 Fax +44 (0)1420 87301 www.rg-racing.com Email: info@rg-racing.com



NOTICE DE MONTAGE

- En vous référant au schéma d'assemblage 1 de la page 2, placez un boulon M6 (article 2) dans une bobine B0544 (article 1).
- Placez le trou dans le cadre près de la poupée de la moto (voir flèche dans la photo A à la page 1) et placez l'extrémité exposée du boulon dans l'orifice de manière à ce que le côté plat de l'économiseur de sécurité se trouve sur le cadre, comme dans l'illustration A logo montrant à l'extérieur.
- **Vissez avec précaution l'écrou Nyloc M6 (article 3) sur le filetage et serrez jusqu'à pincer suffisamment le cadre pour maintenir la bobine de protection en place de sorte qu'elle ne puisse pas tourner. Ne serrez pas trop car le nyloc maintiendra le boulon serré.**
- Répéter pour les deux côtés.
- Testez votre direction pour vous assurer qu'aucun câble ou câblage ne reste coincé entre le bras de la fourche et la bobine, ou ne se coince pas sur la protection lorsque vous les tournez.
- Vérifiez régulièrement le serrage de la protection.

ISSUE 1 05/09/2019 (DM)

R&G Racing

Unit 1, Shelleys Lane, East Worldham, Alton, Hampshire GU34 3AQ.

Tel: +44 (0)1420 89007 Fax +44 (0)1420 87301 www.rg-racing.com Email: info@rg-racing.com



Montageanleitung für LS0010 LENKERANSCHLÄGE

BMW S1000RR 2019-



Abbildung A

ALLE KIT-TEILE SIND UNTEN ABGEBILDET UND GEKENNZEICHNET

DIE ABGEBILDETEN TEILE DIENEN LEDIGLICH ZUR ERKLÄRUNG.

ÜBERPRÜFEN SIE, DASS ALLE TEILE VORHANDEN SIND, BEVOR SIE MIT DER MONTAGE BEGINNEN.

LESEN SIE DIE MONTAGEANLEITUNG KOMPLETT DURCH, BEVOR SIE ANFANGEN.

WENN SIE UNSICHER SIND BEI DER MONTAGE DIESES PRODUKTES, BITTE EINEN UNSERER HÄNDLER KONTAKTIEREN ODER DAS KIT VON EINEM QUALIFIZIERTEN

Die Verpackung der Teile stellt nicht die Reihenfolge der Montage dar.

Hinweis für Kits mit Plastikunterlegscheiben an den Schrauben – Diese Plastik-Unterlegscheiben werden nicht für den Einbau benötigt!

EINE DIGITALE VERSION DIESER MONTAGEANLEITUNG KANN AUF FOLGENDER SEITE HERUNTERGELADEN WERDEN:

www.rg-racing.com

R&G Racing

Unit 1, Shelleys Lane, East Worldham, Alton, Hampshire GU34 3AQ.

Tel: +44 (0)1420 89007 Fax +44 (0)1420 87301 www.rg-racing.com Email: info@rg-racing.com



<u>SIE BENÖTIGEN FOLGENDES WERKZEUG</u>	<u>ALLGEM. ANZUGSDREHMOMENT</u>
<ul style="list-style-type: none"> • 4mm Inbusschlüssel • 10mm Steckschlüssel 	M4 SCHRAUBE = 8Nm M5 SCHRAUBE = 12Nm M6 SCHRAUBE = 15Nm M8 SCHRAUBE = 20Nm M10 SCHRAUBE = 40Nm M12 SCHRAUBE = 40Nm

LIEFERUMFANG

ARTIKEL NR.	BESCHREIBUNG	QTY
ARTIKEL 1	B0544 LENKERANSCHLAG-BOBBIN	2
ARTIKEL 2	M6 x 25mm SENKSCHRAUBE	2
ARTIKEL 3	M6 SELBSTSICHERNDE MUTTER	2

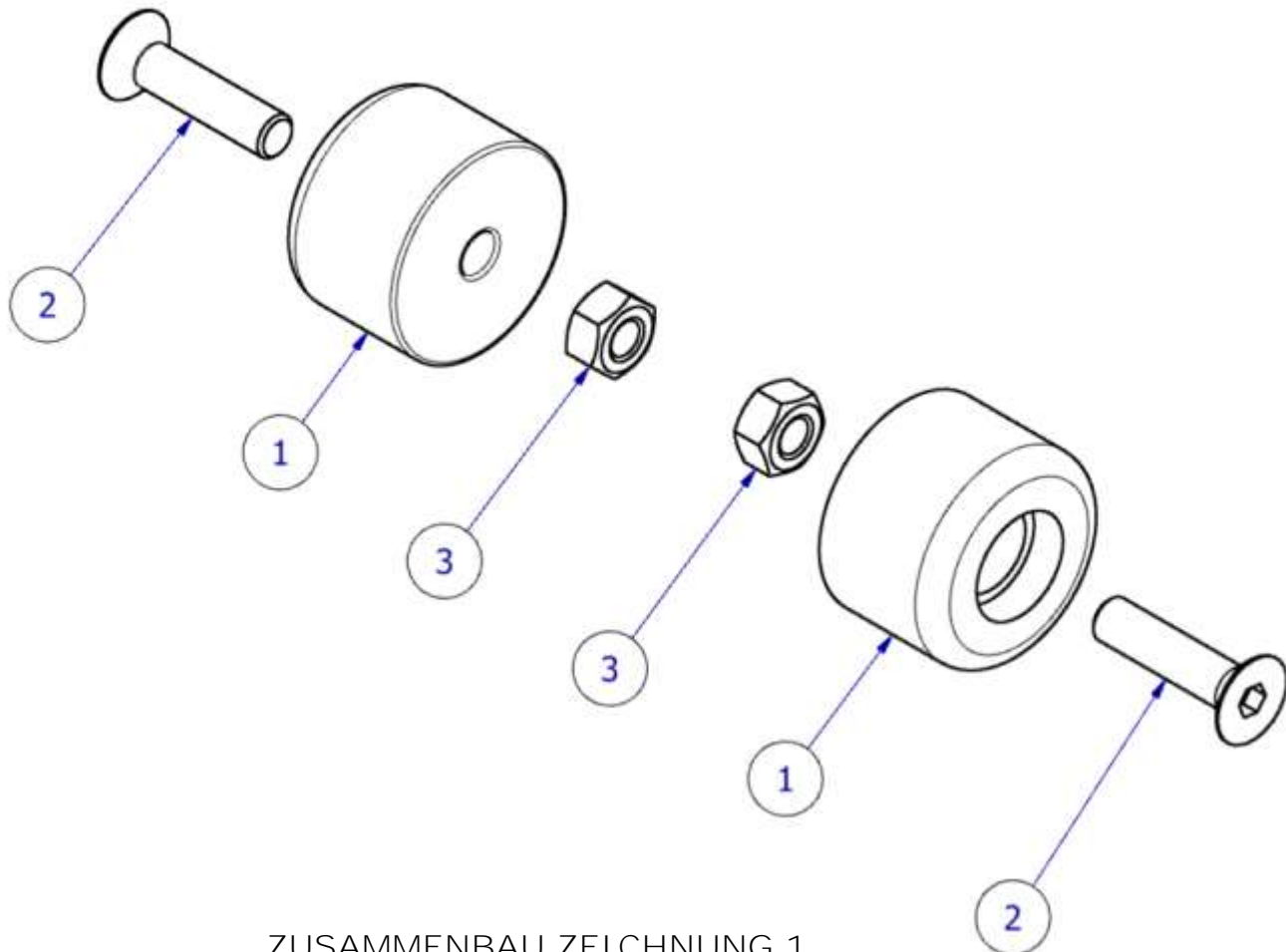

ZUSAMMENBAU ZEICHNUNG 1

R&G Racing

Unit 1, Shelleys Lane, East Worldham, Alton, Hampshire GU34 3AQ.

Tel: +44 (0)1420 89007 Fax +44 (0)1420 87301 www.rg-racing.com Email: info@rg-racing.com



MONTAGEANLEITUNG

- In Anlehnung an der Zeichnung Zusammenbau Zeichnung 1 auf Seite 2, führen Sie eine M6 Senkschraube (Artikel 2) in ein B0544 Lenkeranschlag-Bobbin (Artikel 1) ein.
- Die Öffnung am Rahmen in der Nähe des Steuerkopfes (in Abbildung A auf Seite 1 mit einem Pfeil gekennzeichnet) orten und das Ende der Schraube in die Öffnung einführen, so dass die flache Seite des Lenkeranschlags auf dem Rahmen ist (das Logo nach außen gerichtet).
- Die M6 selbstsichernde Mutter (Artikel 3) am Gewinde anbringen und festziehen bis sie den Rahmen einklemmt und den Lenkeranschlag in Position festhält, sodass der Lenkeranschlag sich nicht drehen kann. Nicht zu fest ziehen, die selbstsichernde Mutter hält die Schraube fest.
- Diese Schritte an der anderen Seite wiederholen.
- Überprüfen Sie den Lenker, um sicherzustellen, dass die Kabel nicht zwischen dem Federbein und dem Sturzpad eingeklemmt werden können oder sich nicht verhaken können, wenn der Lenker bewegt werden.
- Überprüfen Sie regelmäßig, dass die Lenkeranschlänge ordnungsgemäß befestigt sind.

AUSGABE 1 05/09/2019 (DM)

R&G Racing

Unit 1, Shelleys Lane, East Worldham, Alton, Hampshire GU34 3AQ.

Tel: +44 (0)1420 89007 Fax +44 (0)1420 87301 www.rg-racing.com Email: info@rg-racing.com